

Liquid-Activated Retractable CIP Spray Nozzle

Evaporator Dryer Technologies, Inc.



Flush mount nozzle in open position.



Double-wall flush mount nozzle in open position.

EDT's liquid-activated retractable CIP Spray Nozzles are superior components designed specifically to remain in place during production in sanitary food processing applications.

The CIP spray nozzles feature a liquid-activated spray head that fully extends under liquid pressure during CIP and fully retracts after CIP. Large rotating spray jets provide a high impact scrubbing action that ensures complete cleaning of the equipment.

The nozzle is USDA Accepted for sanitary operations and can be easily removed for inspection.

Features and Benefits

- ▶ Liquid-activated design uses less utilities and hookups for operation. No airlines required.
- ▶ Fully retractable spray head. Allows nozzle to remain in place during production without causing process disturbance.
- ▶ USDA accepted for sanitary process applications. Can be completely removed for inspection.
- ▶ Large spray range cleans hard to reach areas. Configurations: forward spray, back spray, lowflow
- ▶ Complete stainless steel construction.
- ▶ Designed with minimal number of components compared to other type nozzles. No breakable or leaking parts.
- ▶ Easy to assemble. No tools required.
- ▶ Available with 1" or 2" liquid connection.
- ▶ Ferrule mount or flush mount for uncladded, cladded and cladded/insulated vessels.
- ▶ Retrofits existing spray devices with EDT mounting ferrule.

Evaporator Dryer Technologies, Inc. provides the services of custom design, engineering and supply of evaporators, spray dryer systems and components with an innovative approach that will modernize and improve plant performance and operational safety.



Evaporator Dryer Technologies, Inc.

1805 Ridgeway Street • Hammond, Wisconsin 54015 USA
Tel. 715.796.2313 • Fax. 715-796-2378

Website: www.evapdryertech.com • Email: info@evapdryertech.com

Liquid-Activated Retractable CIP Spray Nozzle

Evaporator Dryer Technologies, Inc.

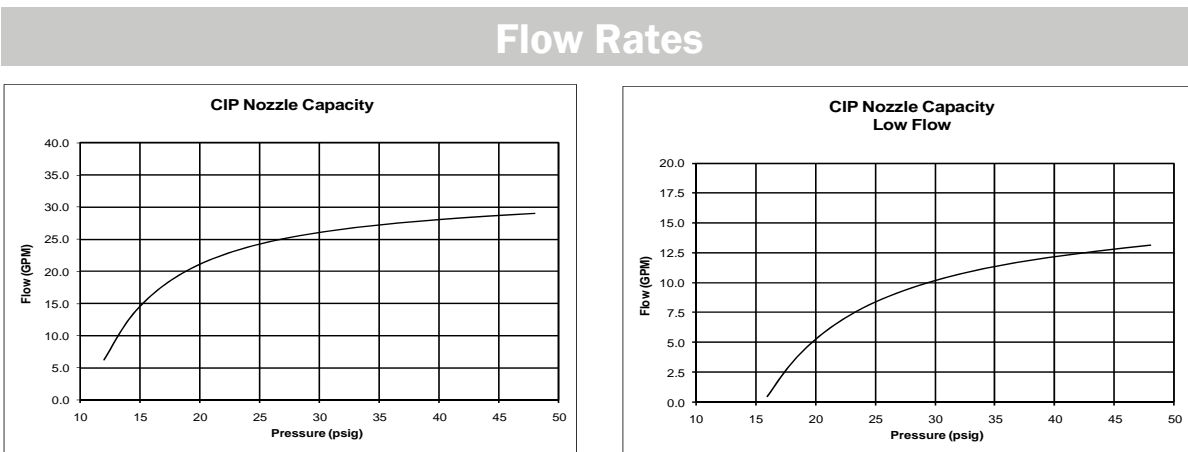
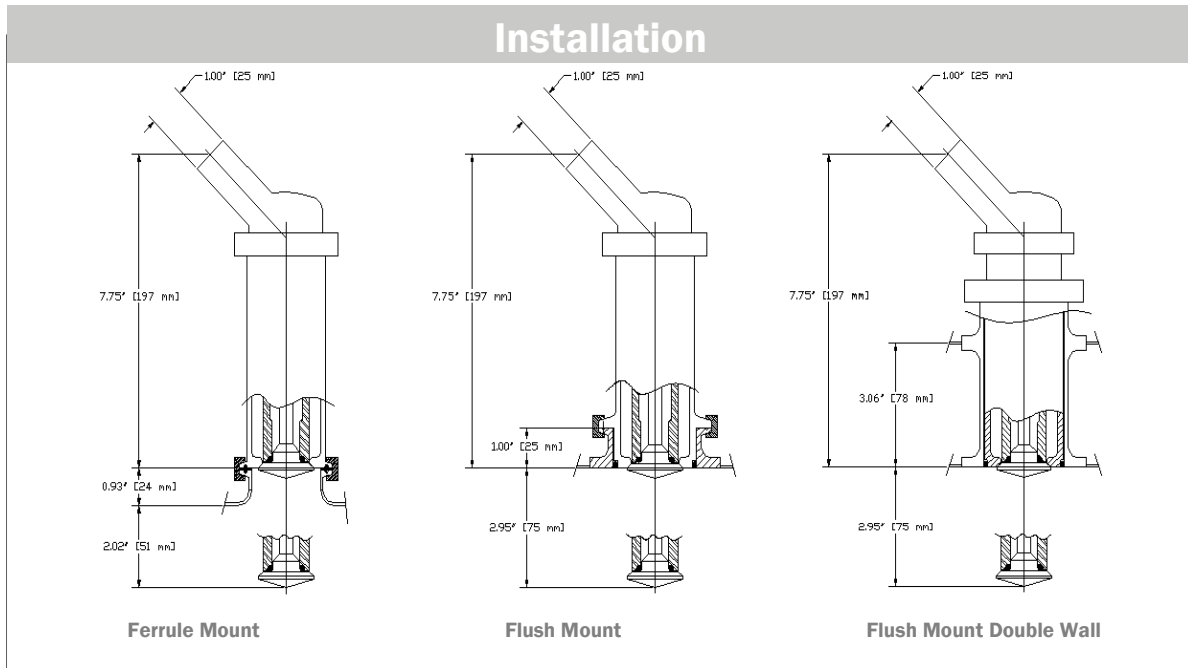

Specifications

<p>Material: 316 stainless steel</p> <p>Liquid Pressure: 25 - 40 psig opening pressure 10 psig</p> <p>Flow Rates: 25 GPM; low flow 10 GPM</p>	<p>Spray Jet: 360° x 200° coverage 8 - 12 feet diameter</p> <p>Spray Pattern: Forward, back, custom</p>
--	---



Evaporator Dryer Technologies, Inc.

1805 Ridgeway Street • Hammond, Wisconsin 54015 USA
Tel. 715.796.2313 • Fax. 715-796-2378

Website: www.evapdryertech.com • Email: info@evapdryertech.com